

DIGITAL DASH CLUSTER 1984-1987 BUICK REGAL

THE BUICK REGAL, GRAND NATIONAL TURBO, T-TYPE AND LIMITED WERE ALL OFFERED A DIGITAL DASH CLUSTER OPTION THAT UTILIZED VACUUM FLUORESCENT DISPLAYS. ALTHOUGH THE CIRCUITRY AND COMPONENTRY ARE COMMON BETWEEN THE MODELS, THERE ARE SOME SUBTLE DIFFERENCES IN THE DASH LAYOUT. THIS ARTICLE WILL SPELL OUT THESE DIFFERENCES AND SHOW YOU SOME OF THE ELECTRICAL FAULTS UNCOVERED IN THE REPAIR AND RESTORATION OF THESE DASH CLUSTERS.



Regal with bench seat, column shift.



**Regal with turbo engine option.
Turbo boost indicators for low
and high boost display.**

Over a course of time and temperature extremes, components on these dash clusters had a tendency to fail, causing many different problems to surface. Perhaps the most common problem is when the MPH segment goes dim intermittently, or goes off completely. This is almost always caused by a pair of overheated resistors soldered to the display PC board. The purpose of these resistors is to reduce brightness of the VFD displays for night driving.

Because of the excessive current load across the resistors, they tend to heat up considerably, causing the soldered component leads to become unstable and loose. The resulting poor solder joint reduces the display brightness well below where it should be, causing a blank display or very dim display.

This is a “good” display board showing what the resistors should look like when soldered correctly. No solder joint discoloration here.

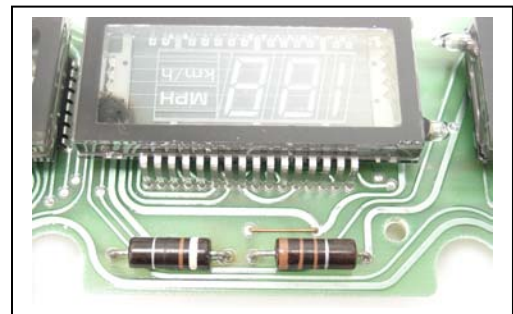

This display board was removed from a car with 47,000 miles. You can see the heat damage to the resistor connections.

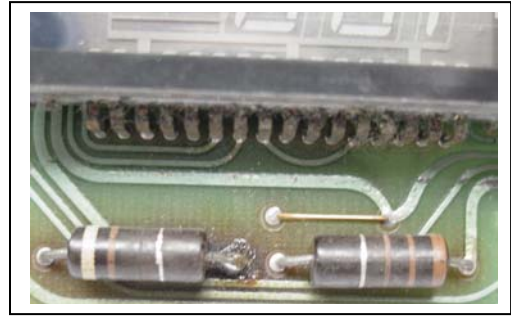

Repairing this damage involves removal of the resistors and sometimes grafting a copper footprint conductor onto the original trace on the circuit board. The excessive heat from these resistors burn the fiberglass PC board and surrounding copper solder pad and traces attached to the pad.

Another common problem with the digital cluster is when the entire cluster goes blank, where there are no segments illuminated. Typically, this is caused by a failed power supply which is piggy-backed to the processor PC board. The power supply on these digital clusters supplies 5 volts for the logic circuit and 18 volts for the VFD display system. There are two slightly different power supplies used between the years; the 1984 and 1985 model years use a supply with an external RF choke coil, mounted behind the cluster face, and the later 1986-1987 model years use an RF choke mounted directly to the power supply PC board.



Early power supply board using external RF choke remotely mounted.

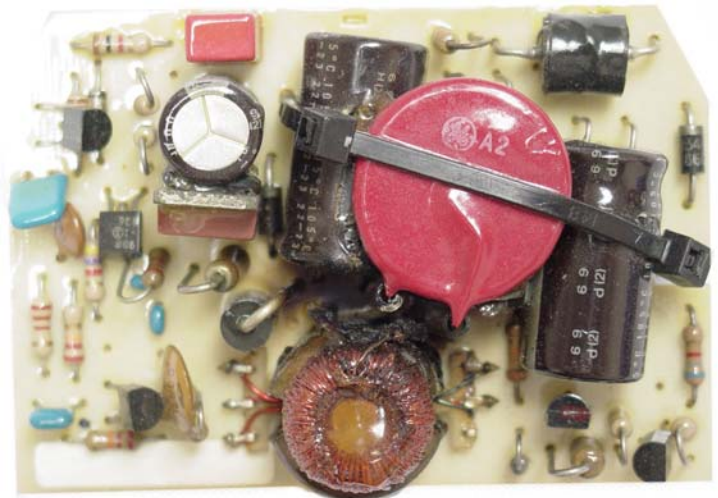

Later power supply with the RF choke mounted on top of the toroid transformer.

When the “dead dash” condition is diagnosed, the defective power supply must be replaced.

Another frequent problem with the cluster is a dead “ODOMETER” display. The VFD odometer display is a separate readout and is physically close to the KM/MPH reset knob and for this reason, is prone to physical stress which can break the fragile vacuum tube. Damage occurs when the odometer reset button is pushed too hard, causing the PC board to flex and bend, stressing the display tube and fracturing the glass seal.

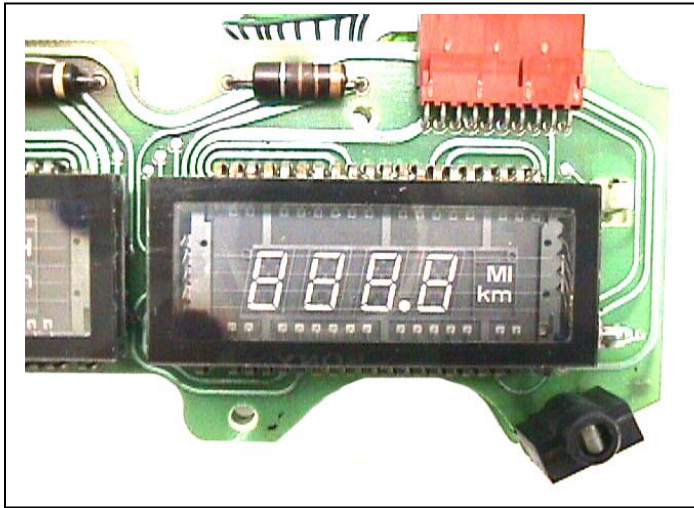

Trip Odometer VFD display mounted onto the display PC board.



Fractured VFD display. Note the white spot in lower left corner.

When the display is damaged, the lower left corner turns white, indicating absence of vacuum in the display. When this happens, the VFD display must be replaced.

The reset knob on the dash cluster is designed to turn and push, allowing operator control for two functions. Turning the reset knob toggles the dash display to read in metric or English, displaying MPH or KM. Fuel level also toggles from GALLONS to LITERS when metric is chosen. Also, by pushing the reset knob inward, the digital odometer is reset to zero. Because of the fragile design of this switch, it is easily damaged by turning it too firmly, causing internal breakage in the switch. Replacement is necessary when this happens.

Occasionally a dash will become intermittent due to the connection from the digital cluster to the dash harness. The connection is made via an edge-type PC board connection to a specially made connector. The edge connector uses printed fingers which are tin plated from the factory. In time, the tin plating becomes tarnished and oxidized, requiring cleaning and resurfacing.

This edge connector is affixed to the digital cluster and extends through the sub-base. If oxidation is present, the fingers must be cleaned and polished.

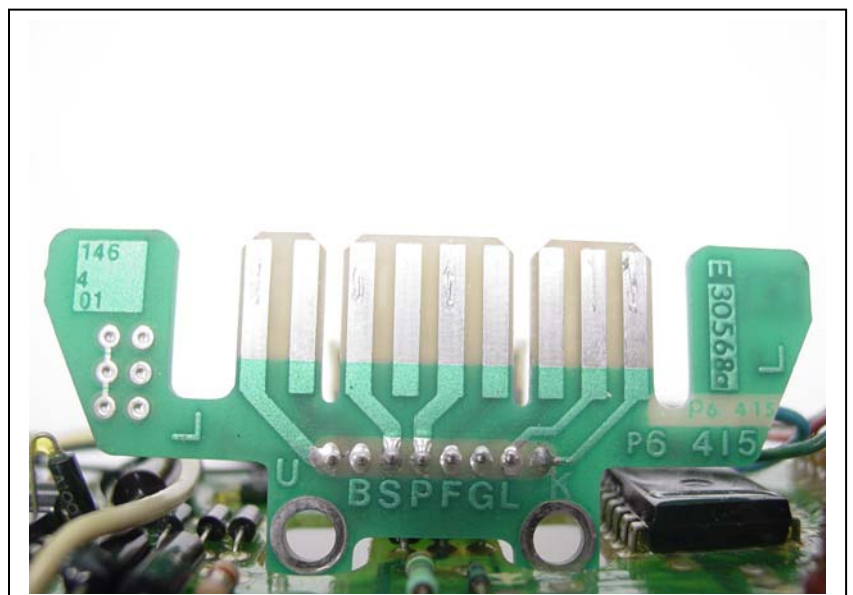

The digital dash was designed to indicate road speeds of up to 85 MPH. Beyond that, the dash would blink a consistent “85” but would not indicate actual MPH if the vehicle was traveling faster. A common upgrade involves a replacement microprocessor chip which allows proper MPH to be displayed, up to the limit of the display, 199 MPH. The PC board shown below has been modified with the 199 MPH upgrade processor IC.

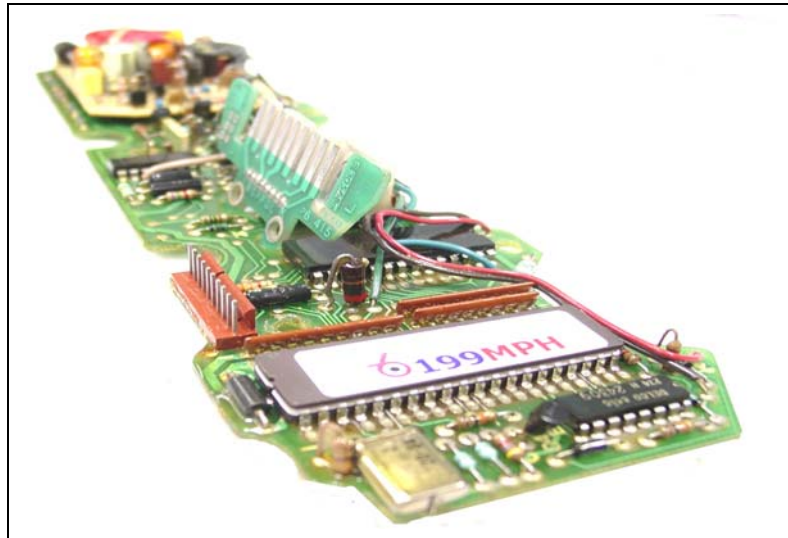

The indicator lights (turn signal, Volts, Service Engine Soon, etc.) that are part of the dash cluster are not directly related to the digital dash but complete the dash display. There are three basic types of “wedge” indicator lamps found on the dash. The brightest lamps have a green holder, type 168 – brown bead, and dimmest bulbs have a black holder with type 167 – blue bead. The gray holders use type 194 wedge lamps (white bead) which is about mid brightness. There is a pair of blue tinted bulbs in brown holders that illuminate the mechanical odometer on the dash cluster. Also, on some vehicles, there is an alternator indicator (VOLTS) that is specially designed with a 470 ohm carbon resistor across its contacts. This bulb has a white cover on the rear of the holder. This special bulb is designed to maintain field current to the alternator in the event that the bulb should burn out (which would cause the alternator to stop charging).

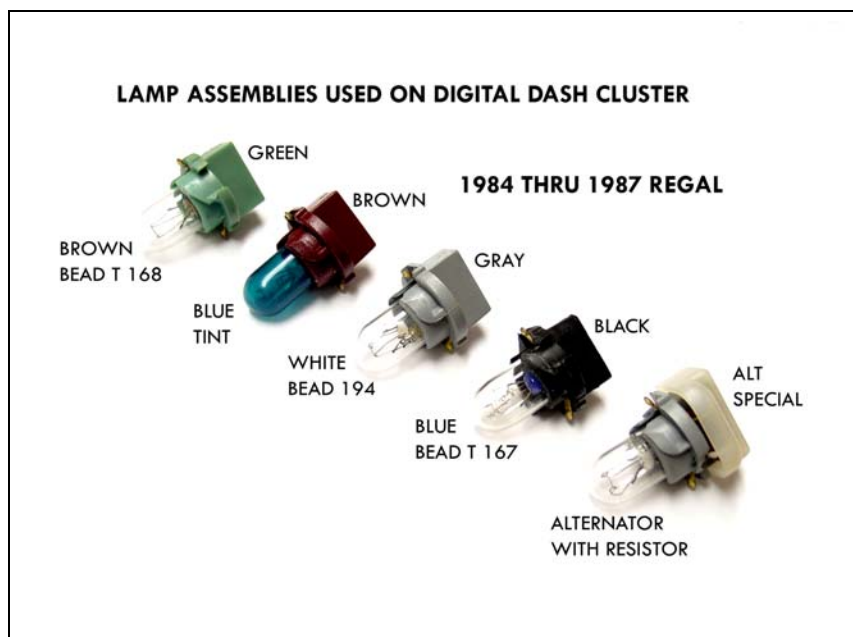

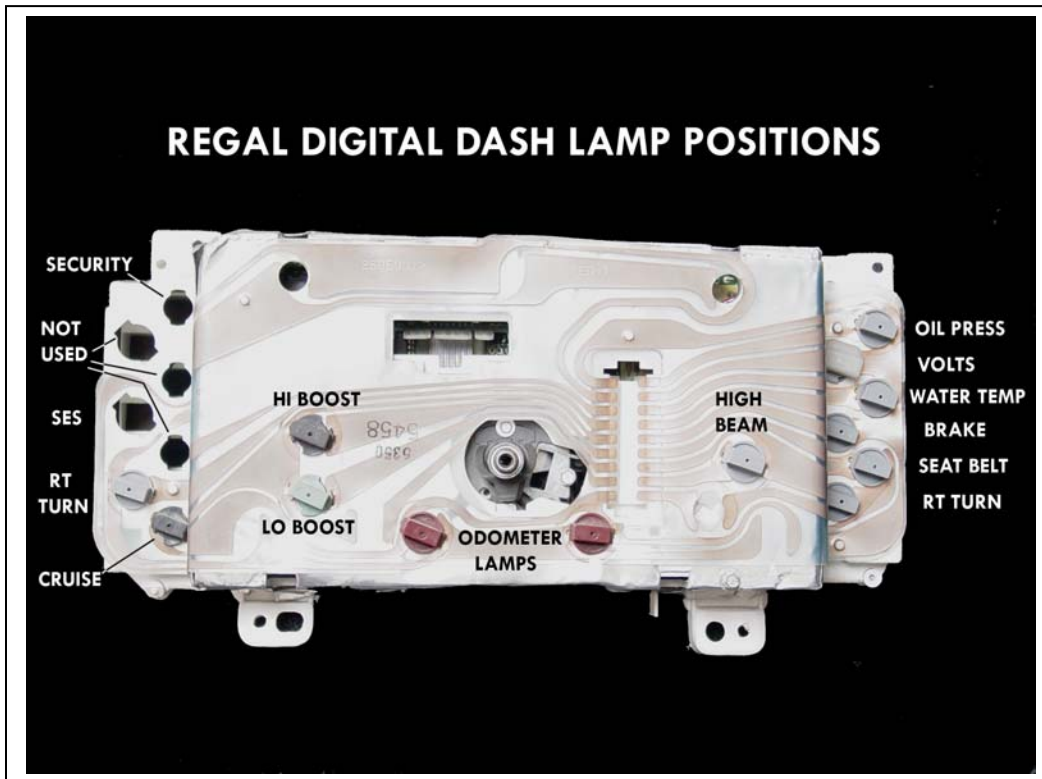

The flex board affixed to the rear of the dash cluster is susceptible to corrosion and tarnishing of the copper conductors, causing a poor electrical connection. Also, because of the contact design on the lamp holders, it is possible to actually rub through the copper conductors, causing an intermittent connection. Since the alternator requires field current which flows through the VOLTS lamp, a bad connection here could prevent the alternator from charging the battery.

To minimize electrical problems with this flex board, it is recommended that you remove the cluster, and remove all of the lamp holders, then gently rub all exposed copper conductors with a pencil eraser to remove oxidation from these conductors. This should also be done in the plug connection area as shown below:

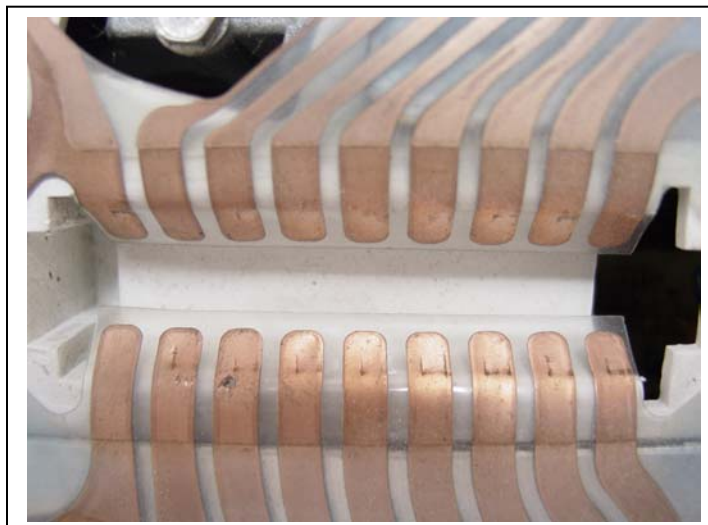

Turbo boost levels are indicated by a simple, two-light display located at the lower right side of the dash, labeled "TURBO POWER". This design merely indicates low boost (in yellow) and high boost (in orange). The low boost is preset to illuminate the yellow lamp at 2.5PSI. The high boost is preset at 10PSI.

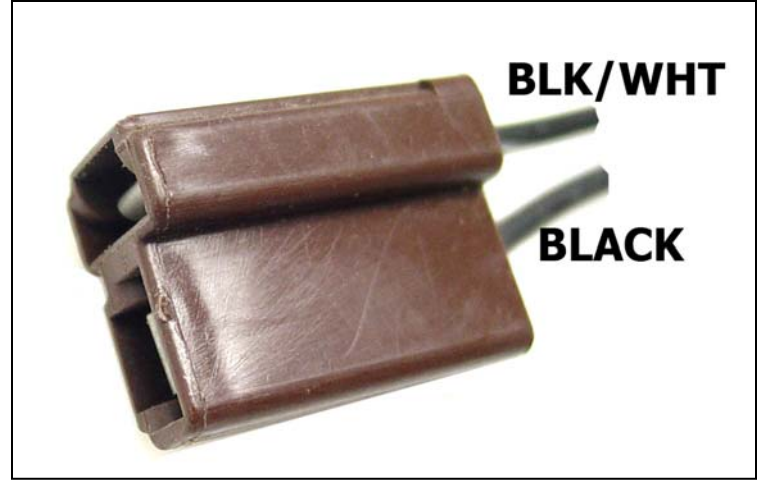

The control switch is located on the inner fender, passenger side, on the bracket that secures the FUEL, AC, and ESC modules. The switch itself is a grounding-type pressure switch with two terminals. The connector is a brown, two wire, unsealed female style.

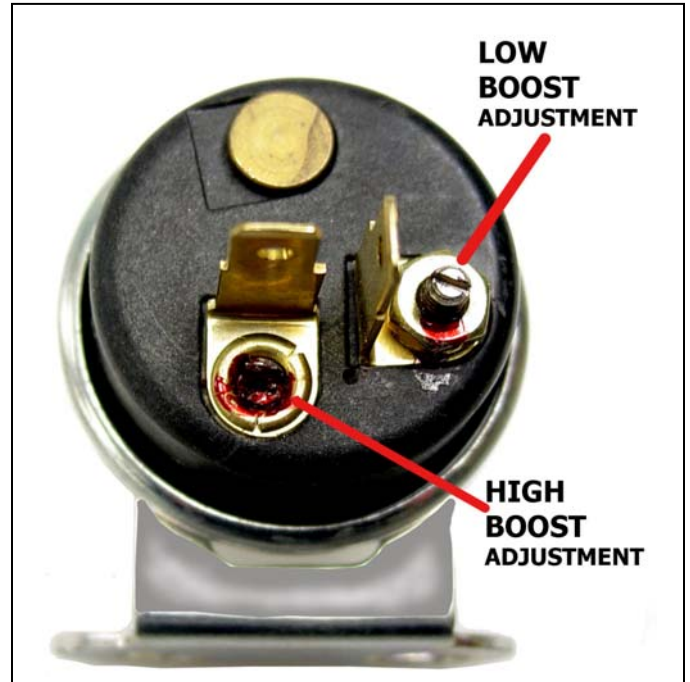
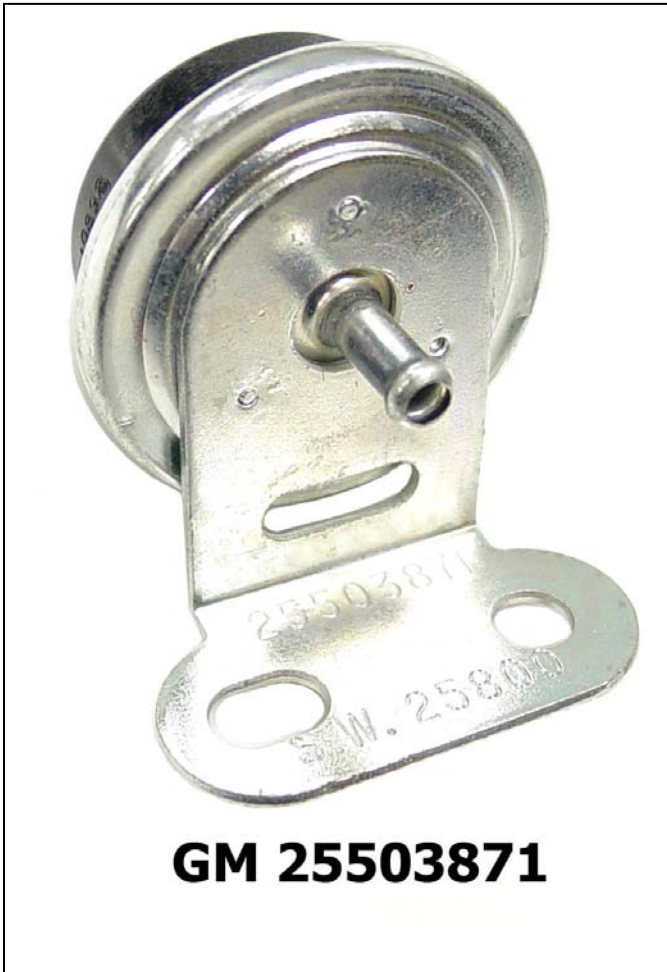

Pressure turn-on settings are preset from the factory. The pressure settings are adjusted using the set screws shown in this illustration. Adjustment can be checked using a hand pressure pump with accurate gauge and an ohmmeter.

Always check the vacuum hose connection to the switch for cracks and leaks when troubleshooting boost display malfunctions. A leak could prevent lights from illuminating.

REMOVING SCRATCHES FROM THE PLASTIC LENS AND TELLTALE FILTER LENSES

Scratches can develop from years of cleaning the dash lens and surrounding indicator lenses. They are made of soft acrylic plastic and scratch easily. The best way we have found to remove minor scratches and swirl marks is to use a product designed to remove scratches from CD's and DVD's. Here is one such product:

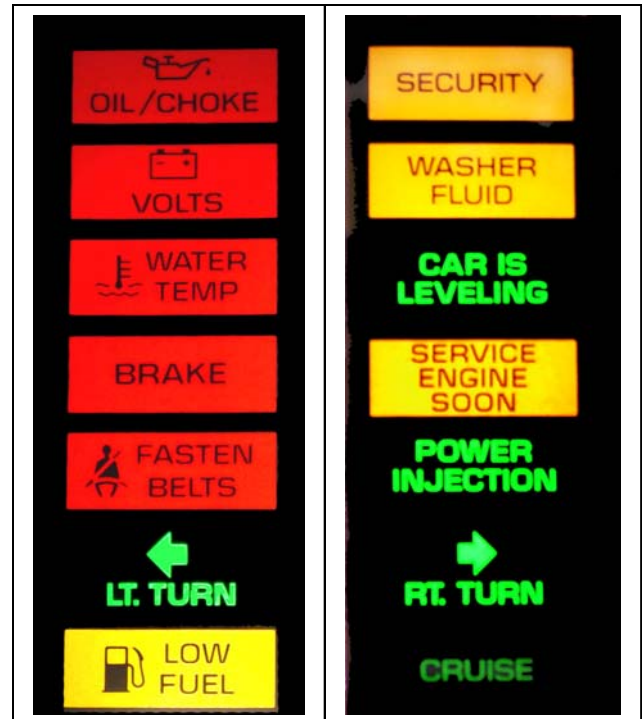

These are the Telltale filters found on either side of the dash cluster. Minor scratches and swirl marks can easily be removed.

Carefully remove the cluster lens and both of the Telltale filter lenses on either side of the dash. Follow the instructions with the scratch remover product and don't rub too hard as the scratch remover is slightly abrasive. **DO NOT ATTEMPT TO CLEAN THE BLACK PAINTED DIAL OF THE CLUSTER FACE.** The semi-flat painted finish on the dash dial is very sensitive to any type of abrasion and will show fingerprints and smudges **VERY** easily. It is best left alone and should be cleaned with only dry compressed air.

The smoke-gray filter that's positioned over the digital display segments should not need cleaning, and only minor dusting of this filter is necessary.

The mechanical odometer movement should not be disturbed and should not require cleaning or adjustment.

Here is a factory component breakdown of the parts used on the digital dash:

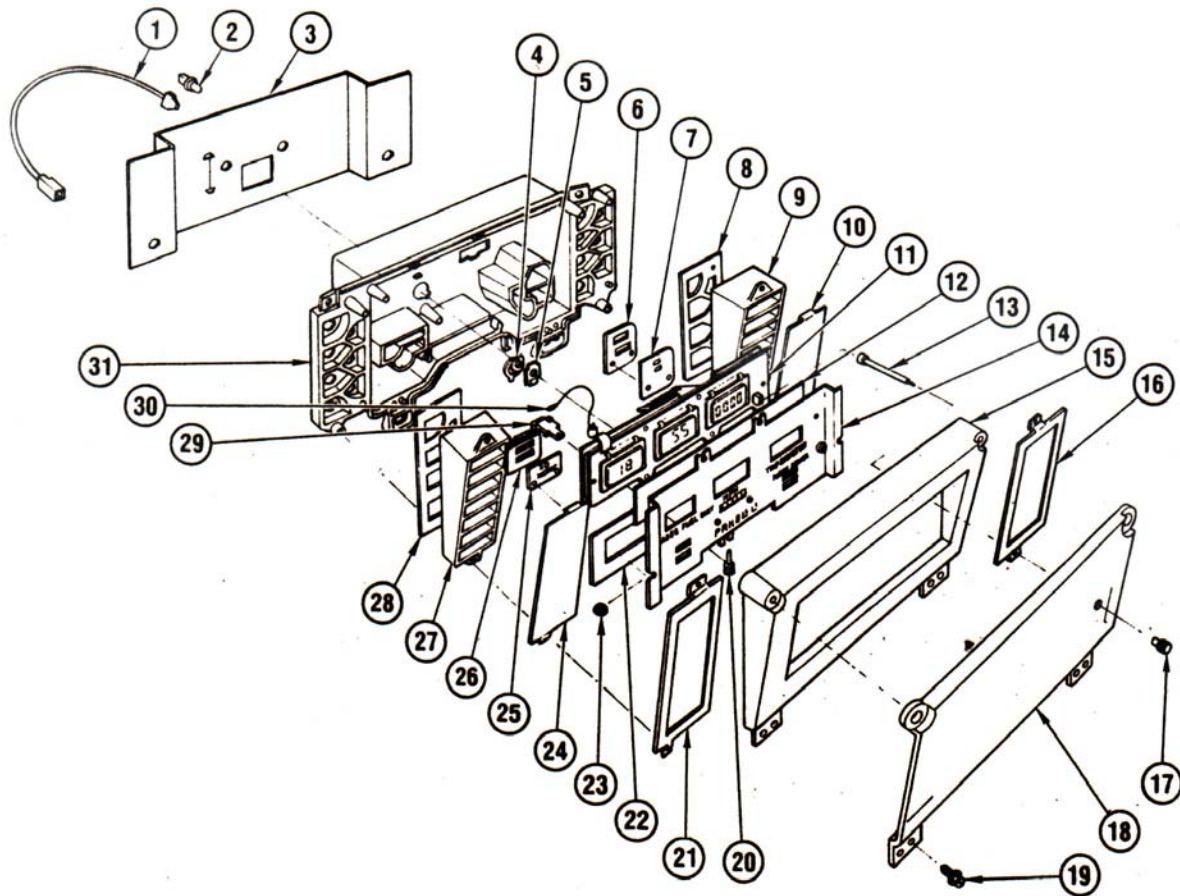

1.	3.682	SENSOR, Veh Spd	25007227	15.	9.747	RETAINER, Cluster Lens	25018721
2.	8.965	SOCKET, Wedge Base Lamp		16.	9.748	RETAINER, Telltale-RH	25018737
3.	9.744	PRINTED CIRCUIT,	25050012	17.	9.761	KNOB, Trip Odom Reset	25017970
4.	9.761	CLIP, Speedo Cbl Ret	25016200	18.	9.748	LENS, Instr Cluster	25024581
5.	9.761	GASKET, Speedo	25044639	19.	N.S.	SCREW, Hex Hd	
6.	9.749	GASKET, Dial Telltale	25049929			(M3.5x1.34x19)	
7.	9.748	FILTER, Light (Diesel)	25049604	20.	4.020	POINTER, Shift Indicator ..	25018744
	9.748	FILTER, Light (Exc Diesel) ..	25049606	21.	9.748	RETAINER, Telltale-LH	25018738
8.	9.749	GASKET, Telltale Housing-RH	25021840	22.	N.S.	GASKET, Display Filter	
9.	9.765	HOUSING, Telltale-RH	25021834	23.	9.761	BUSHING, Speedo Mtg	25017001
10.	9.748	FILTER, Telltale-RH	25048475	24.	9.748	FILTER, Telltale-LH	25045251
11.	N.S.	PRINTED CIRCUIT, Display ..		25.	9.748	FILTER, Hi Beam	25049998
12.	N.S.	FILTER, Display		26.	9.749	GASKET, Hi Beam Filter	25049997
13.	N.S.	SHAFT, Trip Odom Reset		27.	9.765	HOUSING, Telltale-LH	25021835
14.	9.761	DIAL, Fuel, MPH, Trip Odom		28.	9.749	GASKET, Telltale Housing-LH	25021841
		(Turbo) (3.108)	25049601	29.	4.020	LINK, Shift Indicator	25047898
	9.761	DIAL, Fuel, MPH, Trip Odom		30.	4.020	CABLE, Shift Indicator	25017439
		(Diesel) (3.108)	25049602	31.	9.743	CASE, Cluster	25053620
	9.761	DIAL, Fuel, MPH, Trip Odom				(Exc Turbo/Diesel) (3.108) ..	25049600